



# next

*Shoulder Solutions*®

## REVERSE SURGICAL TECHNIQUE



CE 2292

# SURGICAL TECHNIQUE METAL GLENOID BASEPLATE



## Glenoid exposure :

Expose the glenoid fully using the three types of retractors.

Anterior retractor,  
Superior retractor,  
Inferior retractor.

Remove the glenoid labrum. Remove any potential osteophytes to expose the full bone anatomy.

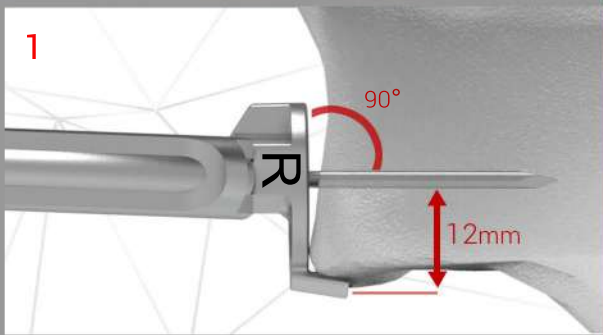

## Placing the K-wire:

Three different positions for the guide: Left (L), Right (R) for a deltopectoral approach and Superior lateral (S).

Position the K-wire guide on the inferior part of the glenoid to determine the correct height.

The K-wire is 12mm above the lower edge, and must be centered in the antero-posterior plan.

The K-wire guide orientation is important for the glenoid tilt and must be done at 90° (see picture 2). The glenoid spheres are tilted (lower lip) by 10°. Positioning should be to fit the anatomy of the patient and planned according to pre-operative X ray.

This element must be decided in pre-operative planning. By default, the base plate is perpendicular to the mid plane of the glenoid.

Insert K-wire by power tool.

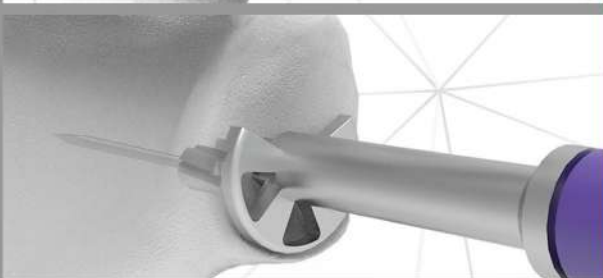
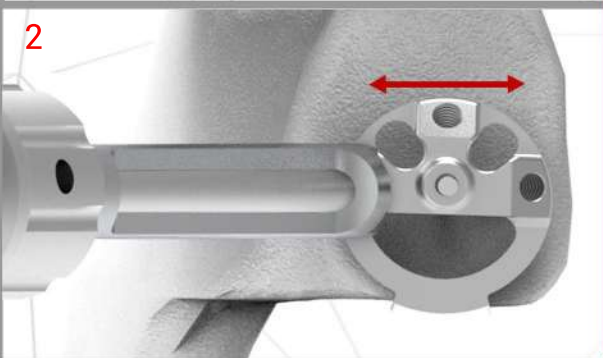

## Glenoid reaming:

Drill and ream the glenoid using the K-wire guide. Ream until the subchondral bone is reached.

This step can be done by power or by hand if the glenoid is porotic.

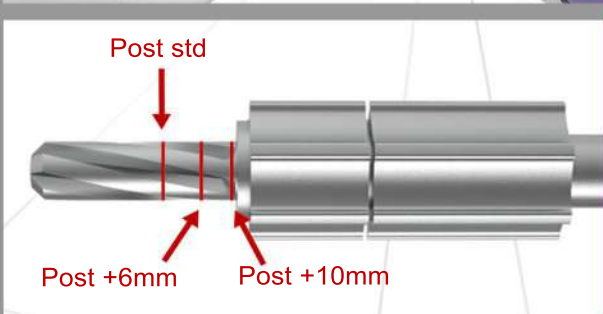

## Extension post:

In the case of revision or lateralisation of the center of rotation with a graft from the pillar of the scapula, it is possible to extend the post by 6 or 10 mm.

Tighten the block-stop in the correct position by screwing it onto the drill to either 6 mm or 10 mm, as required.

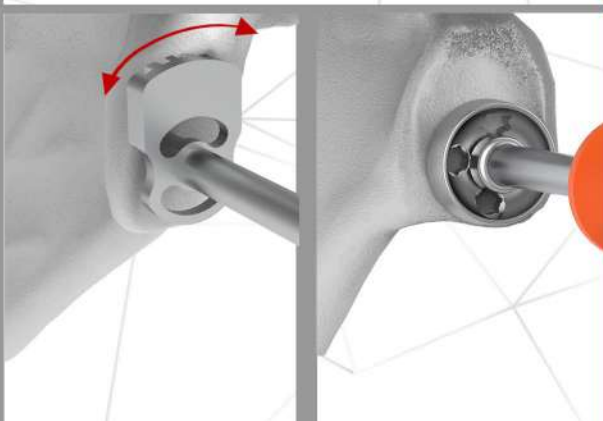

## Glenoid clearance:

To avoid any interference between the glenosphere and the scapula, ream the glenoid using the Ø40 mm hand reamer.

## Positioning the baseplate:

Connect the holder / impactor to the baseplate. Impact the baseplate so that there is pressure over the whole surface. The impactor allows for the upper and lower holes to be placed so that a screw can be positioned in the base of the coracoid and in the pillar of the scapula.

The sign (UP) must be on top under the coracoid basis.



### Length of screws (5 sizes from 20 to 40 mm):

An adapted guide allows for the holes to be drilled and the length of the screws measured with the Ø 3.2 mm drill bit. The length of the screws are measured directly. It is possible to drill up to the 2nd cortex and use the gauge to measure the screw length. The screw length is measured from under the head.

Two types of screws are available, locking or standard.



### Fixation of the baseplate:

Standard screws allow the baseplate to be lagged to the bone, and locking screws fix the mounting. Each screw allows an angulation of +/-12° around the axial hole.



### Glenosphere trial:

There are two diameters of glenospheres: Ø36 and Ø40 mm. And they have centered or eccentric options. Position the glenosphere to the definitive glenoid baseplate.



### Trial Humeral Cup:

The cup diameter matches the glenosphere diameter. And 6 sizes heights are available. (+3,+6,+9,+12,+15,+18)

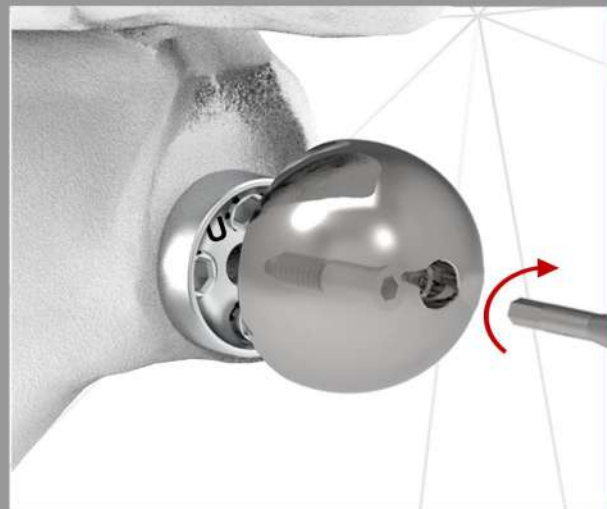

### Fitting of the definitive implants:

Insert the glenosphere paying attention to the 'UP' marking, if an eccentric-glenosphere is used. Introduce the cannulated glenosphere screw to the glenosphere in the post of the baseplate. Be sure to check that the baseplate is clean and free of any bone or tissue particles that could hinder impaction of the morse taper.

- 1- Begin to screw the glenosphere.
- 2- Impact the glenosphere with the impactor.
- 3- Finish screwing

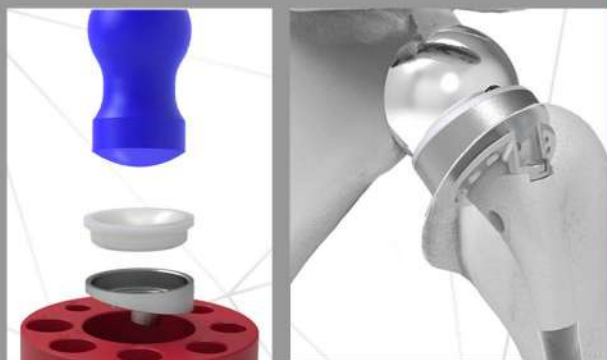

### Humeral Liner:

Open the packaging of the liner and the metal back that was selected during the trial reduction. Assemble the final humeral liner and the metal back on the back table with the use of the modular prosthesis / humeral liner inserter.

# CEMENTED & CEMENTLESS HUMERAL STEM

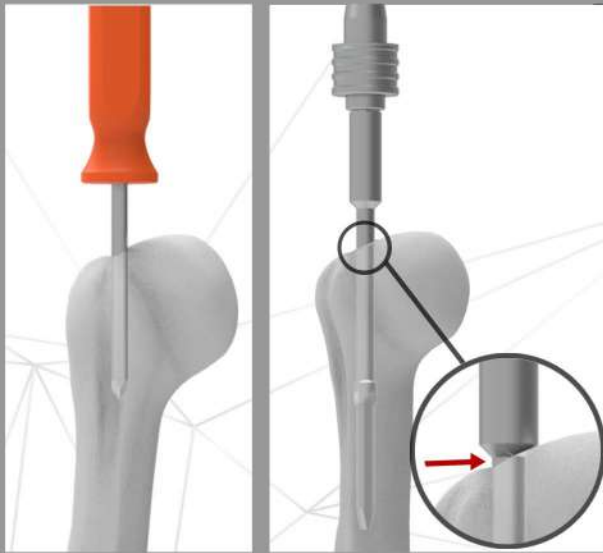

## Preparation of the humeral shaft:

Locate and perforate the top of the humeral head in the medullary canal axis using a triangular awl.

Use the reamers in increasing size order on the T handle. Go from one size to the next until the diameter of the reamer meets the diameter of the shaft.

The reamer should enter the humeral shaft up to the guard. The stem choice is made depending on the last reamer size used:

Reamer Ø08mm	= no cemented types	= cementless Ø08mm
Reamer Ø10mm	= cemented stem Ø08mm	= cementless Ø10mm
Reamer Ø12mm	= cemented stem Ø10mm	= cementless Ø12mm
Reamer Ø14mm	= cemented stem Ø12mm	= cementless Ø14mm

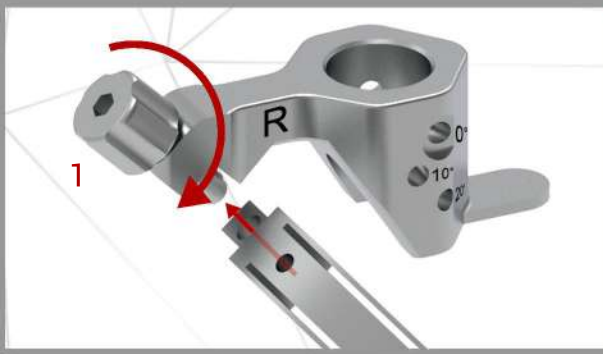

## Mounting the delto-pectoral cutting guide:

Place the delto-pectoral cutting guide on the operating side on the guide holder.

Fasten the guide with the knurled screw (1).

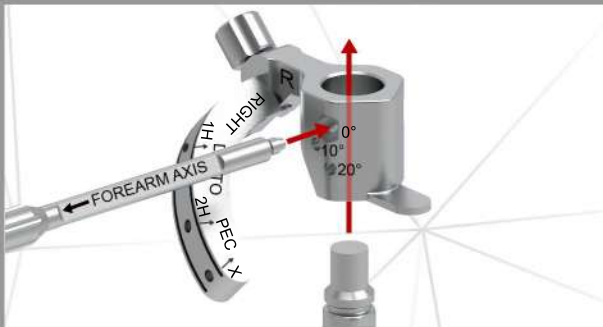

Slide the assembly onto the remaining reamer.

Screw the retroversion stem into one of the three positions according to the required angle: 0°, 10°, 20°.



## Placing the cutting guide:

The probe stops at the top of the head and determines the incision height. The retroversion is determined by screwing the stem into one of 3 positions (0°, 10°, 20°) and aligning it with the forearm axis. Fastening the retroversion stem sets the position for the cutting guide.

Place two pins by drilling if necessary, using the Ø3.2 mm bit.

Remove the retroversion stem and the guide holder as well as the reamer. Slide the cutting guide along the pins. Stabilize the mounting using a 3rd oblique pin.

Make the incision across the slot with a saw blade of a maximum 1.2 mm thickness.

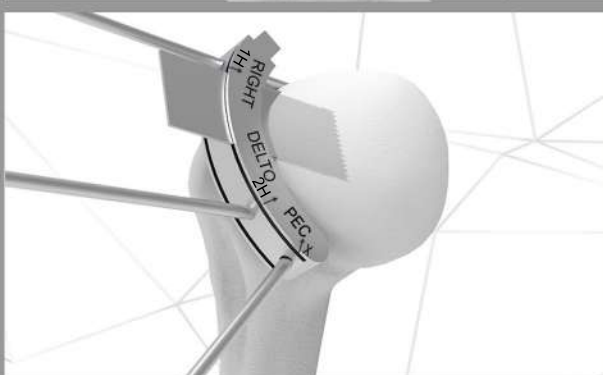

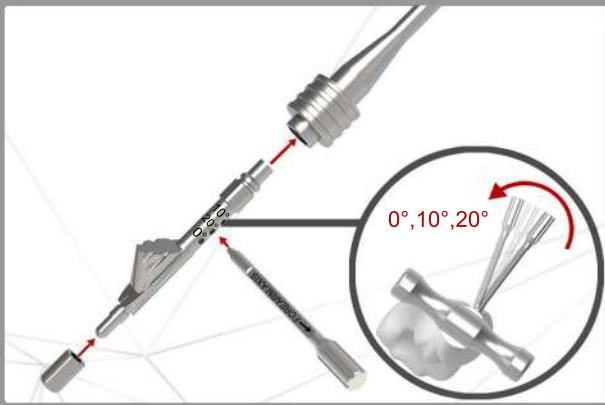

### Puncher + retroversion adjustment:

Mount the retroversion rod from the right or left hand side. The size of the sleeve is determined by the size of the last reamer. Plug the puncher on the T handle. Place the rod parallel to forearm to achieve 0° or 10° or 20° retroversion. Impact the puncher until it meets the resected surface and please do the trial reduction with the true sizes of the humeral body and the distal stem.

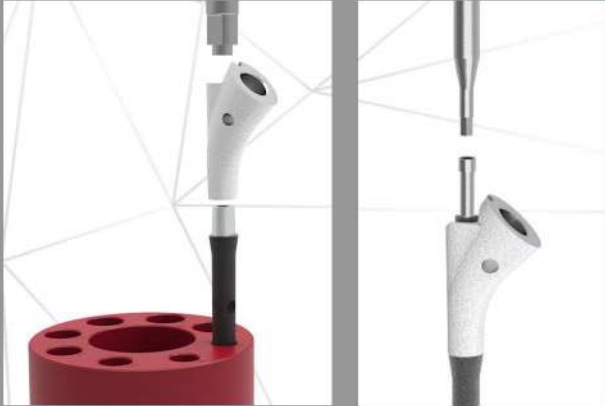

### Fitting the stem:

Open the packaging of the humeral body and the distal stem that was selected during the trial reduction. Assemble the final humeral body and distal stem on the back table with the use of the modular prosthesis / humeral liner inserter.

Then fix the humeral stem with the 3,5 mm connection screw.



### Impactation of the definitive implant:

Mount the impactor onto the implant with the 3,5 mm screwdriver. Place the rod parallel to forearm to achieve 0° or 10° or 20° retroversion.

Insert the stem in the humeral shaft keeping the good retroversion. Stem is in place when the humeral cut.

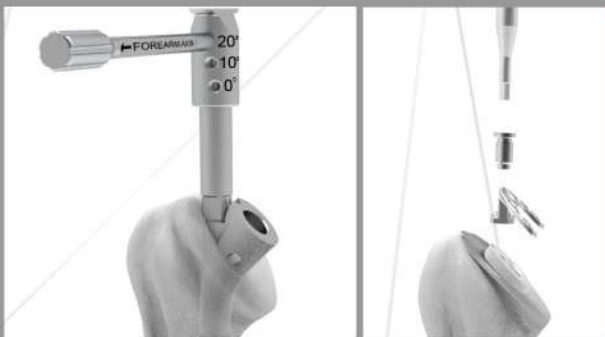

### Fitting the Collar:

Take the appropriate collar implant and fit it on to the stem. Secure using the screw provided for this purpose and the hex 3,5 mm screwdriver.



### Impactation of the Humeral Liner:

Insert the cup into the taper of the stem in the correct position. Check there is nothing impeding impactation of the cup and impact it.



**Proximal interlocking (if needed for the cementless stem):**

After having carefully dissected the soft parts using Halstead forceps, Insert the  $\text{\O}10\text{mm}$  guide into the top hole of the aiming guide until contact is made with the cortex using the soft-tissue holder. Insert the drill guide depth gauge into the  $\text{\O}10\text{mm}$  guide. Leave the distal K-wire in place.

Drill up to and including the 2nd cortex. Use the gauge to measure the screw length. Use screw size L + 2 mm. Screw length is measured from under the head.

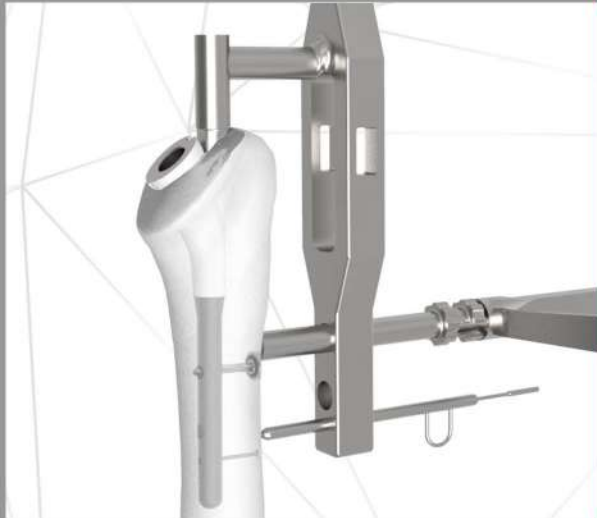

Insert the drill guide depth gauge into the  $\text{\O}10\text{mm}$  guide. Leave the distal K-wire in place. Drill up to and including the 2nd cortex. Use the gauge to measure the screw length. Use screw size L + 2 mm. Screw length is measured from under the head.

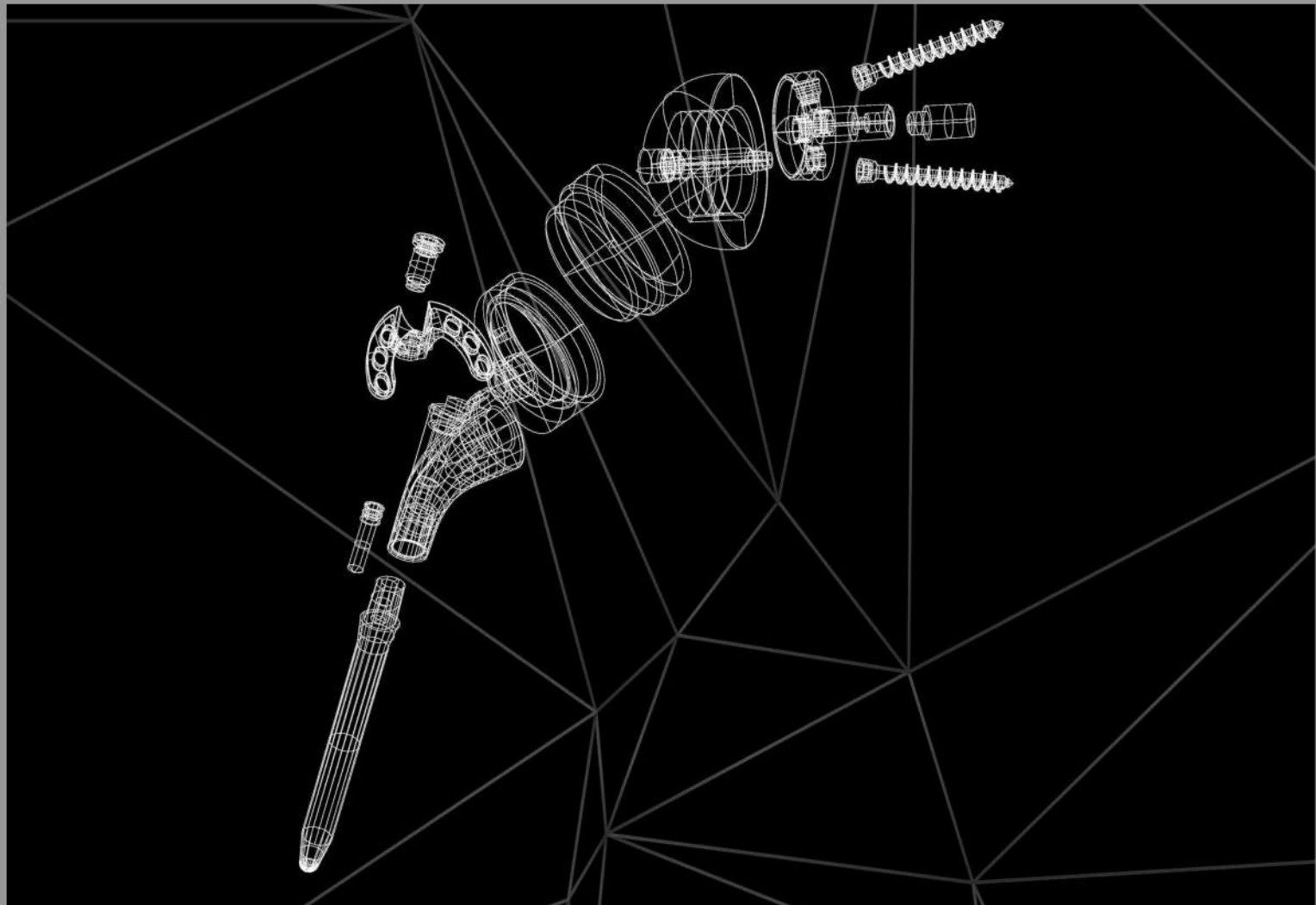



*Improve Life...*

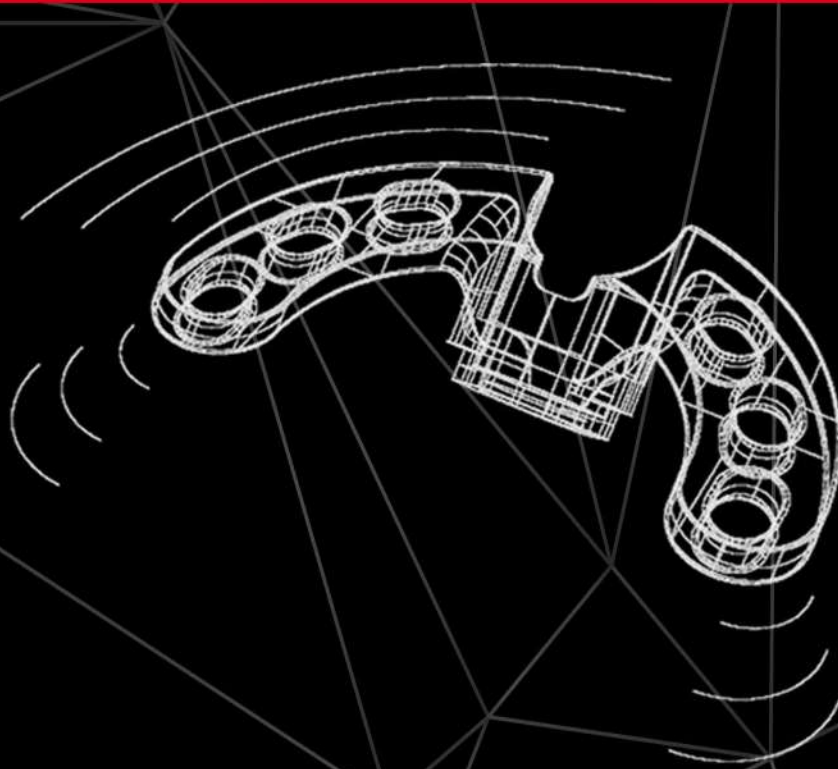

**NEXT SAĞLIK ÜRÜNLERİ A.Ş.**



[www.next.tc](http://www.next.tc)



[quality@next.tc](mailto:quality@next.tc)



+90 312 242 0041



İvedik OSB 88 Oto Sanayi Sitesi 3.Bölge 2284 Cad. No:101 Yenimahalle / ANKARA / TURKEY